

NOTES:-

1) INLET & OUTLET CONNECTIONS MUST BE SUITABLY GUARDED BY CLIENT TO PREVENT OPERATOR ACCESS TO ROTATING/MOVING PARTS IN LINE WITH RELEVANT REGULATIONS (BS EN 294/BS5304:1988 ETC)

2) ALL SAFETY INTERLOCKS MUST BE WIRED INTO MOTOR CONTROL CIRCUIT TO PREVENT THE MOTOR RUNNING OR DE-ENERGISE THE MOTOR IF ALREADY RUNNING SHOULD THE INTERLOCKS BE ACTUATED BY OPENING ANY DOOR. REFER TO INSTRUCTION MANUAL. INTERLOCKS PROVIDED WITH 1 PAIR N/C CONTACTS AND 1 PAIR N/O CONTACTS.

3) SCREEN AREA: 0.32m² (K650C)

4) APPROX NET WEIGHT: 200KG

5) SIFTER SPEED 700RPM. ANTI-CLOCKWISE ROTATION WHEN VIEWED FROM THE OVERSIZE END

6) BOSSES PROVIDED TO FACILITATE EARTH CONTINUITY ACROSS INLET AND FINES OUTLET FLANGES.

DO NOT SCALE DRAWING - IF IN DOUBT ASK

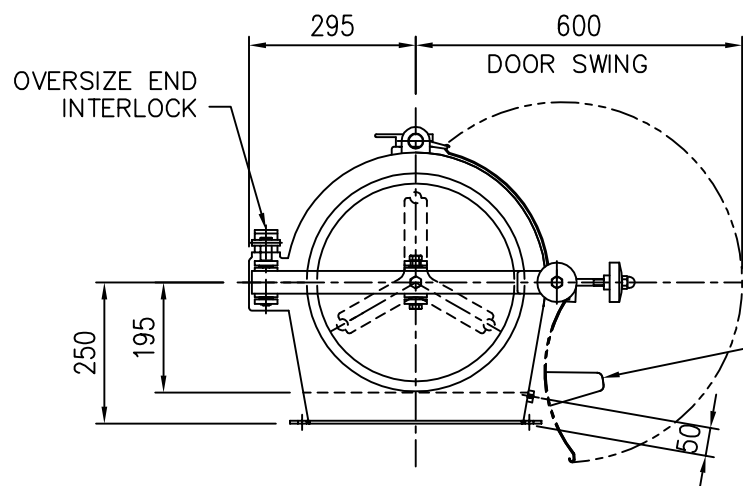
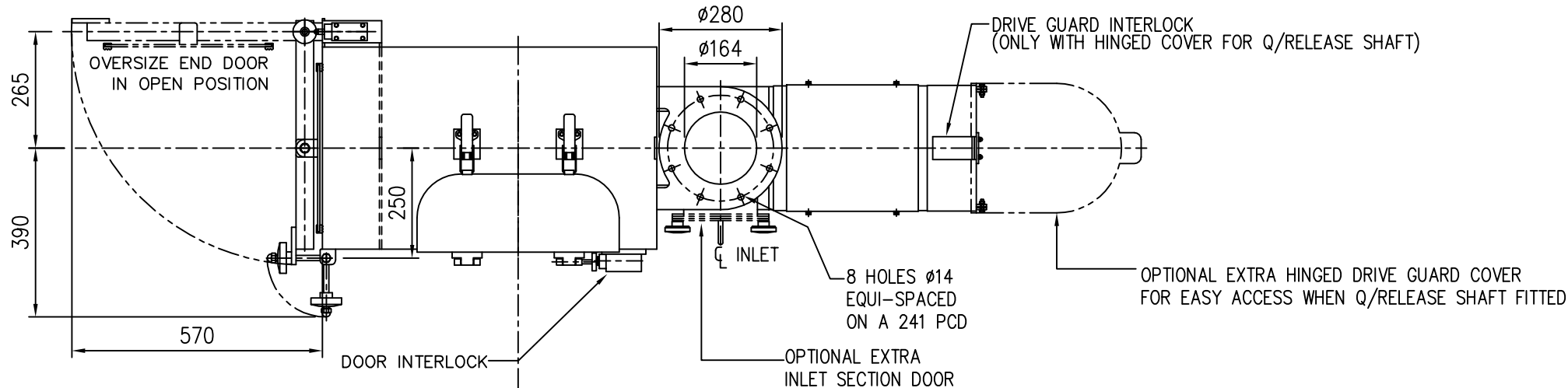

VIEW ON OVERSIZE END

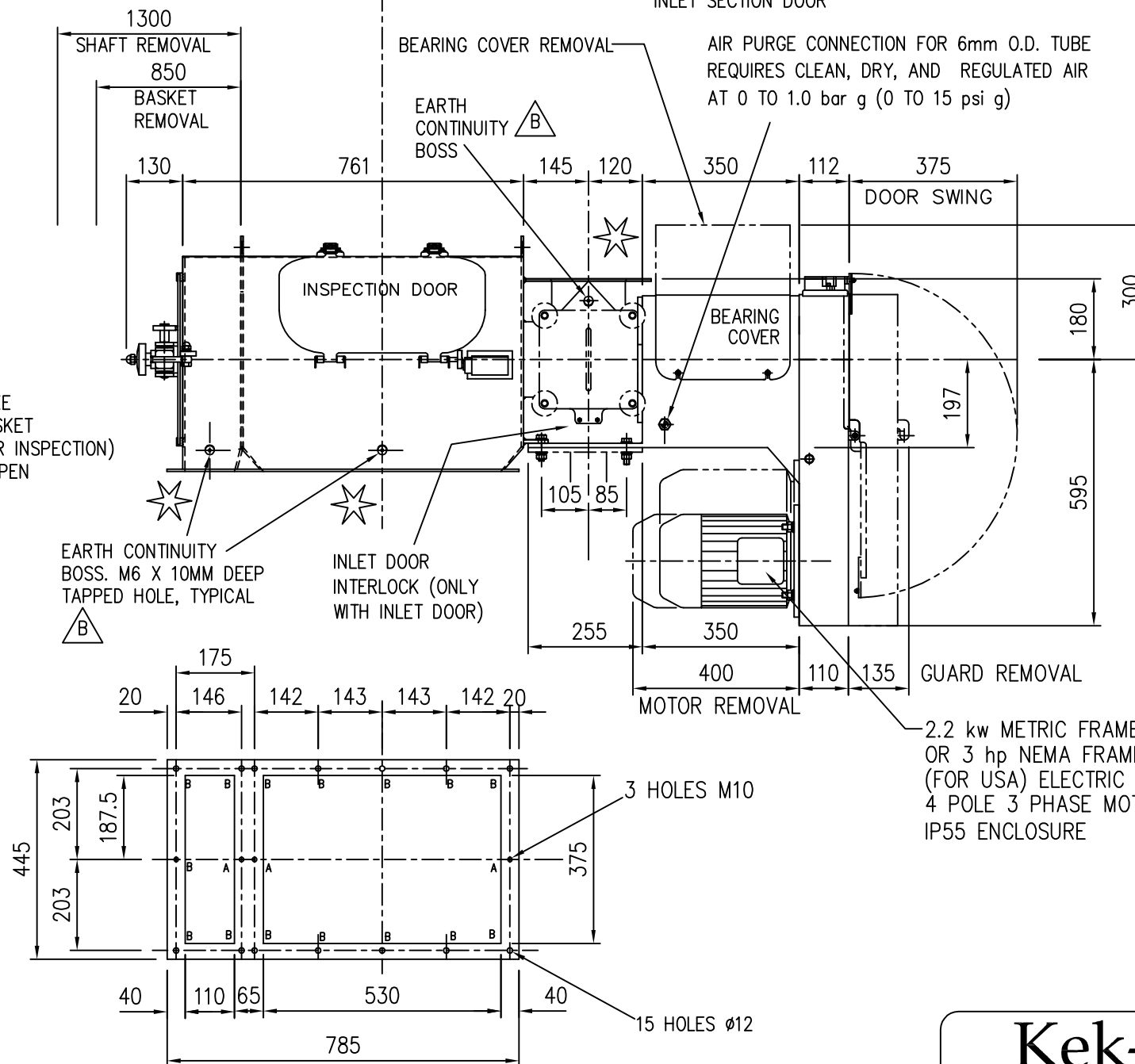

OVERSIZE & FINES OUTLET FLANGE DETAIL

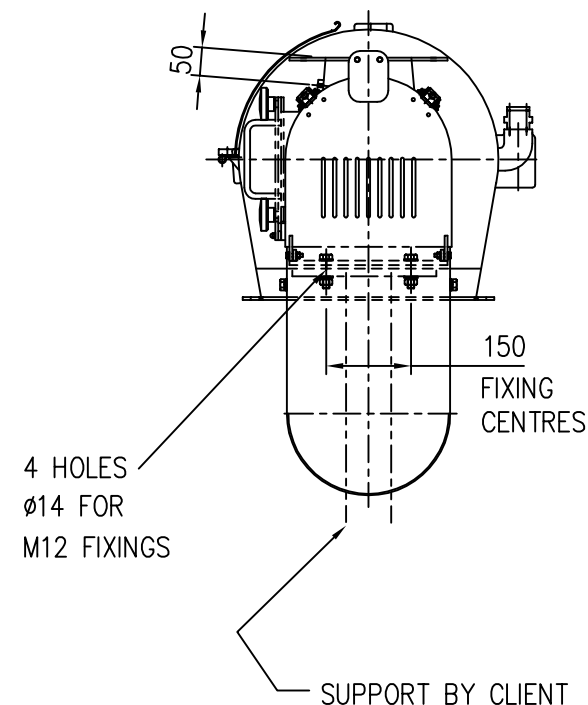

Kek-Gardner
 Kek-Gardner Ltd
 Springwood Way, Macclesfield, Cheshire, SK10 2ND
 Tel: +44 (0)1625 412000 Fax: +44(0)1625 412001

DRAWN BY <i>PJK</i>
CHECKED BY
APPROVED BY
SCALE 1:10
DRAWING No A2 DS487
ISSUE B
DATE 27/04/00

THIS DRAWING IS THE PROPERTY OF KEK-GARDNER LTD AND MUST NOT BE COPIED OR SHOWN TO A THIRD PARTY WITHOUT THE WRITTEN CONSENT OF THIS COMPANY. ©	DRAWING SPECIFICATIONS UNLESS OTHERWISE STATED	TOLERANCE SPECIFICATIONS UNLESS OTHERWISE STATED	ALL DIMENSIONS IN MILLIMETRES	ISSUE B EARTH BOSSES ADDED P.B 26/02/04	TITLE K650C CANILEVER RH DOOR CUT OFF BOTTOM
	Screw threads to BS3643 ISO Metric Coarse Pitch Series (Medium Fit) Surface Finish to BS1134 in micrometres Welding Symbols to BS499 Part 2 Dimension & Geometrical Tolerances to BS308 Limits & Fits to BS4500 Remove all sharp edges and burrs	SHEET METAL DIMENSIONS 0 to 300 ± 1.00 300 to 1000 ± 2.00 Over 1000 ± 3.00 ANGULAR DIMENSIONS ± 0°-30'	MACHINED DIMENSIONS 0 to 150 ± 0.30 Over 150 ± 0.60 UNMACHINED DIMENSIONS 0 to 150 ± 0.50 Over 150 ± 1.50		

NOT PLOTTED